

**PECL/LVPECL HF XO  
AB-X29SXXX-X Series**

**Description**

The **AB-X29SXXX Series** of crystal oscillators (XO) provides high frequency with PECL/LVPECL complementary outputs. The outputs can be disabled for test automation or combining multiple clocks. The device does not use any frequency multiplication, providing exceptionally low Phase Noise and Jitter. It is packaged in a miniature, FR-4 based 9x14 mm SMD package.

**Applications and Features**

- Wide frequency range – 12.0MHz to 280.000MHz
- Fiber Channel; 10 GbE; Infiniband; Network Processors; SONET/SDH
- High Reliability - NEL HALT/HASS qualified for crystal oscillator start-up conditions
- Ultra Low Phase Noise, Low Jitter
- No Multiplication
- SONET ±20ppm overall free-run stability available
- High shock resistance, to 1000g
- COTS/Dual use

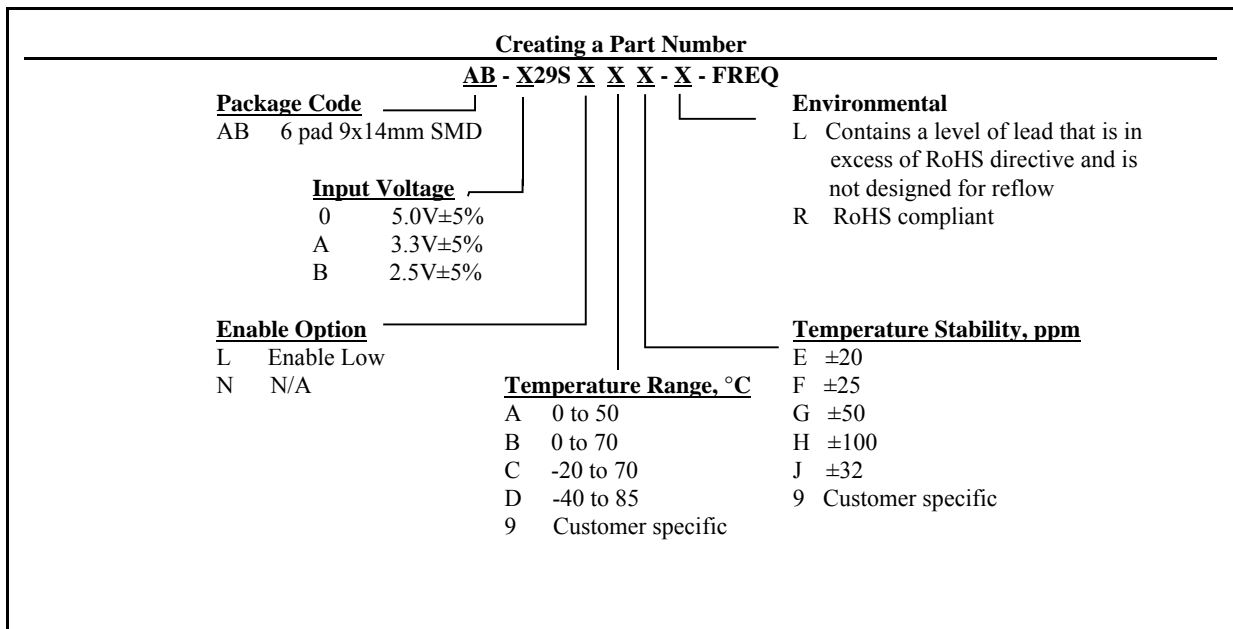

AB-X29SXXX-X Series Continued  
PECL/LVPECL XO

Rev. F

## Absolute Maximum Ratings

Parameter	Symbol	Value	Unit
Operating Temperature Range	To	-40 to +85	°C
Storage Temperature Range	Tst	-50 to +90	°C
Supply Voltage	Vcc	-0.5 to 5.5	V
Enable/Disable Voltage	Ven/dis	0 to Vcc	V

## Electrical Parameters (1)

Parameter	Symb	Conditions, Note	MIN	TYP	MAX	Unit	
Nominal Frequency	Fo		12		280	MHz	
Supply Voltage	Vcc	Code 0 Code A Code B	4.75 3.135 2.375	5.0 3.3 2.5	5.25 3.465 2.625	V	
Supply current	Icc	Vcc=5.0V		60	80	mA	
Output Logic Type				PECL/ LVPECL			
Load		Output to Vcc-2V, or Thevenin Equivalent		50		Ohm	
Output Levels	Voh Vol	overall	Vcc- 1.025		Vcc- 1.620	V	
Duty Cycle (Symmetry)		At 50% of output voltage swing	45/55	50/50	55/45	%	
Rise/Fall Time	Tr/Tf	20 to 80, 80 to 20 %		0.5	0.7	ns	
<b>Jitter</b>	Integrated	J	Integrated from Phase Noise, 12 KHz to 20 MHz, RMS		0.1	0.2	ps
						1.0	ps
					0.3		ps
	Wavecrest characterized		Random period, Accumul., pk-to-pk Deterministic		2.5		ps
					17		ps
					0		ps
Sub-harmonics				None		dBc	
Phase Noise	£(Δf)	155.52 MHz	@ 10 Hz @100 Hz @1 KHz @10KHz @100KHz @>1MHz	-75 -105 -128 -142 -147 -147	-70 -100 -125 -140 -145 -145	dBc/Hz	
Frequency Stability	ΔF/F	Overall, including initial calibration, temperature, aging 10 years, shock and vibration	±20	See "Creating a Part Number"		ppm	
Enable		Pin 2 = Low, 0 to Vcc- 1.62V or floating	Enabled			V	
Disable		Pin 2 = High, Vcc-1.025V to Vcc	Disabled, Pin 4 = Logic "1", Pin 5 = Logic "0"			V	

Note 1. All parameters, unless otherwise specified, are at nominal conditions, ie: T=25°C, Nominal Vcc & Nominal Load.



**FREQUENCY  
CONTROLS, INC.**

357 Beloit Street, P.O. Box 457, Burlington, WI 53105-0457 U.S.A. Phone 262/763-3591 FAX 262/763-2881

Email: [nelsales@nelfc.com](mailto:nelsales@nelfc.com) www.nelfc.com

## AB-X29SXXX-X Series Continued PECL/LVPECL XO

Rev. F

### Electrical Connection

Pin	Connection
1	N/C
2	Enable/Disable
3	V <sub>EE</sub>
4	Output
5	Output Complement
6	V <sub>CC</sub>

Outline tolerance:  
±0.015"/0.4mm  
(Unless otherwise specified)

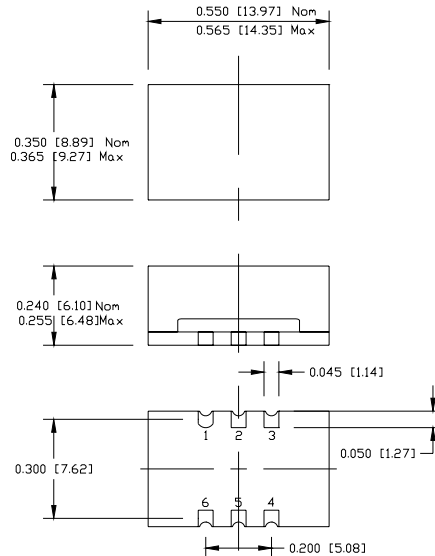

OUTLINE TOLERANCE:  
±0.015" / 0.4mm  
(Unless otherwise specified)

All dimensions: Inches [mm]

### RECOMMENDED PAD LAYOUT

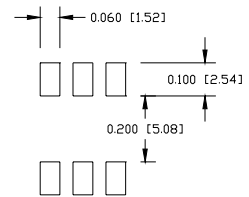

## Environmental and Mechanical Characteristics

<b>Operating temp. range</b>	see part # table
<b>Mechanical Shock</b>	Per MIL-STD-202, Method 213, Cond. E
<b>Thermal Shock</b>	Per MIL-STD-883, Method 1011, Cond. A
<b>Vibration</b>	Per MIL-STD-883, Method 2007, Cond. A
<b>Hermetic Seal</b>	Leak rate less than $1 \times 10^{-8}$ atm.cc/s of helium
<b>Soldering conditions</b>	See MAX reflow profile below; The device may be reflowed once. Reflowing upside down is not allowed. NO CLEAN assembly is recommended

### Maximum Reflow Profile

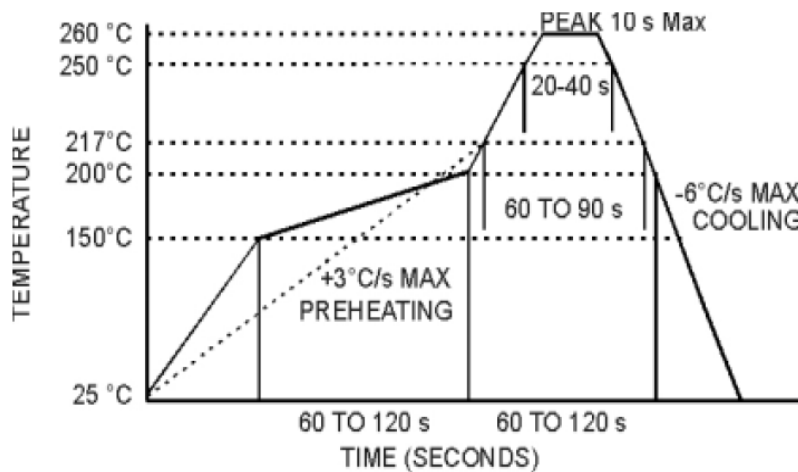

The device may be reflowed once. Reflowing upside down is not allowed. NO CLEAN assembly is recommended